

# FERRI<sup>®</sup>

Offset in-line slope mowers

**ZMTE**  
**PRO**







The new model of side shredder ZMTE PRO, is the ideal solution for the cleaning of edges of plots of land, ditch banks, and generally green areas.

The external positioning of the multiplier unit allows to operate totally outside the tractor track in absolute safety, suitable for tractors from 60 to 80 HP.

As standard, the ZMTE PRO model is equipped with the DOMEX subframe to avoid damage to the frame itself and the innovative mechanical shock absorber to protect the whole machine in case of impact against obstacles. Recommended for grass, bushes, shrubs and wood up to 4 cm in diameter.

## Offset in-line slope mowers



### SAFETY

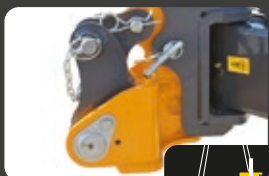

Mechanical locking pin for transportation, (no chains, no brackets).

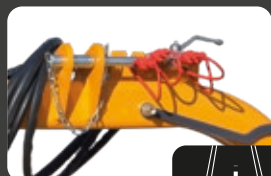

Flailhead hydraulic lock tap.



Gearbox external to the drive housing.

### RELIABILITY



Mechanical shock absorber device (protection in case of obstacles).



Lateral parallelogram offset with protected adjustable hydraulic cylinder.

# FERRI®



**ZMTE PRO 1600**  
**ZMTE PRO 1800**  
**ZMTE PRO 2000**

## PERFORMANCE



Inner lining "Full coverage" Domex 700 Steel.



Internal rotor bearings.



Floating flail body frame, self-leveling to the ground.

## TECHNICAL



Rounded frame edge.



Rotation joint on self lubricating bushing.







## Offset in-line slope mowers

Technical data		ZMTE PRO		
Model		1600	1800	2000
Width of cut	ft	5' 5"	6' 1/2"	6' 8"
Max Sidesliding*	ft	9' 2"	9' 10"	10' 6"
Head angle movement		45°/90°	45°/90°	45°/90°
Weight	lbs	1336	1398	1444
Tractor	HP/PS	60/80	60/80	70/80
Min. Tractor weight	lbs	5291	5291	5732
Min. Tractor width	ft	5' 3"	5' 11"	6' 7"
Pto	MAX Rpm	540	540	540
Blade tip speed	ft/sec	177	177	177

\* Reach measured from tractor centre line to head edge

Flails		ZMTE PRO		
Interchangeable on the same rotor		1600	1800	2000
"Y" blades for: grass, shrubs, bushes	Ø max 1 1/4"	 N° 40	48	48
Forged hammer- blades for: woods, grass, twigs	Ø max 1 3/4"	 N° 20	24	24

Working positions (ft)		ZMTE PRO		
		1600	1800	2000
<b>A</b>	ft	9' 2"	9' 10"	10' 6"
<b>B</b>	ft	6' 6"	6' 6"	6' 6"
<b>C</b>	ft	5' 5"	6' 1/2"	6' 8"
<b>D</b>	ft	1"	1"	1"
<b>E</b>	ft	6' 1"	6' 1"	6' 1"

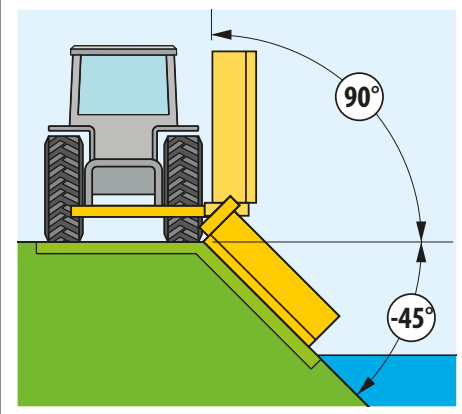
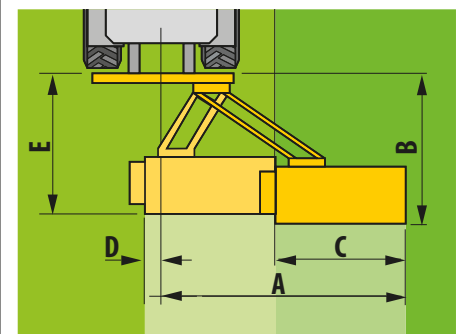

All data subject to change  
campbelladv.com 35021  
ZMTE PRO - USA - EN  
Rev 0 - 35021



**FERRI srl**  
Via Govoni, 30  
44034 Tamara (FE) Italy  
Tel. +39 0532 866866  
Fax +39 0532 866851  
info@ferrisrl.it - www.ferrisrl.it



**North America Sales and Marketing Manager / FERRI**  
Ronald E. Roglis - Glenarm, Illinois 62536  
Cell (314) 422-9460 - Fax (217) 483-4123  
ron.roglis@gmail.com

**Parts Stock / FERRI:**  
J.S. Woodhouse Co., Inc. - 1314 Union Street  
P.O. Box 1169 - West Springfield, Ma. 01090 U.S.A.  
tel. 413-736-5462 - fax 413-732-3786  
info@jswoodhouse.com

www.ferri-america.com